

TREATMENT PLANT APPROVAL 10/2021
Plumbing and Drainage Act 2018

Approval

1. The **OzziKleen GTS10** (“the system”) described in the Specifications and Drawings in the attached Schedule and manufactured by **Neatport Pty Ltd** (“the manufacturer”) (ABN 62 063 770 534) has been assessed in accordance with the Queensland Plumbing and Wastewater Code (QPW Code) dated 26 October 2017.
2. Approval is granted for an advanced secondary greywater treatment system, subject to compliance by the manufacturer with the requirements of the *Plumbing and Drainage Regulation 2019* and the conditions of approval detailed below.
3. This approval, the conditions of approval and the Schedule comprise the entire Treatment Plant Approval document.
4. Any modification by the manufacturer to the design, drawings or specifications scheduled to this approval must be approved by the Chief Executive.

Conditions of approval

5. The manufacture, installation, operation, service and maintenance of the systems must be in conformity with the conditions of this Treatment Plant Approval.
6. The advanced secondary greywater treatment system may only be used on premises that generate per day:
 - (a) a maximum hydraulic loading of 2,000 litres/day; and
 - (b) a maximum organic loading of 600 grams/day BOD₅
7. For the system to meet the requirements of an advanced secondary quality greywater treatment system, the system must produce the following effluent quality —
 - (a) 90% of the samples taken must have a BOD₅ less than or equal 10g/m³ with no sample greater than 20g/m³; and
 - (b) 90% of the samples taken must have total suspended solids less than or equal 10g/m³ with no sample greater than 20g/m³; and
 - (c) 90% of the samples taken must have thermotolerant coliform count not exceeding 10 organisms per 100 mL with no sample exceeding 200 organisms per 100mL.
 - (d) The total chlorine concentration shall be greater than or equal to 0.5gm³ and less than 2.0g/m³ in four out of five samples taken.
8. Each system must be serviced in accordance with the manufacturers details supplied in the owner’s service and maintenance manuals.
9. This approval does not extend, apply to, or include the land application system used in conjunction with an approved system installed on premises.

Treatment Plant Approval

Approved by: Stacey McInnes
Delegated Authority
Department of Energy & Public Works

10. Each system must be supplied with —
- (a) a copy of this Treatment Plant Approval document;
 - (b) details of the system and ancillary equipment;
 - (c) instructions for authorised persons for its installation;
 - (d) a copy of the owner's manual to be given to the owner at the time of installation; and
 - (e) detailed instructions for authorised service personal for its operation and maintenance.
11. At each anniversary of the Treatment Plant Approval date, the manufacturer must submit to the Chief Executive a list of all systems installed in Queensland that they have received an installation and commissioning certificate for during the previous 12 months.
12. Where the Chief Executive is notified of any system failures that they believe are a result of poor design or faulty manufacture, the Chief Executive may randomly select a number of installed systems for audit. The Chief Executive will notify the National Association of Testing Agencies (NATA) accredited laboratory nominated by the manufacturer, which systems are to be audited for Biochemical Oxygen Demand (BOD₅) and Total Suspended Solids (TSS). The sampling and testing of the selected systems, if required, is to be done at the manufacturer's expense. The following results must be reported to the Chief Executive;
- (a) Address of premises.
 - (b) Date inspected and sampled.
 - (c) Sample identification number.
 - (d) Biochemical Oxygen Demand (BOD₅).
 - (e) Total Suspended Solids (TSS).
13. The Chief Executive may, by written notice, cancel this approval if the manufacturer fails — to comply with one or more of the conditions of approval; or within 30 days, to remedy a breach, for which a written notice been given by the Chief Executive.
14. This approval may only be assigned with the prior written consent of the Chief Executive.
15. This approval expires on 01 January 2024 unless cancelled earlier in accordance with paragraph 13 above.

Stacey McInnes
A/Director
Plumbing, Drainage and Special Projects
Building Legislation and Policy
Date approved: 18 March 2021

Treatment Plant Approval

Approved by: Stacey McInnes
Delegated Authority
Department of Energy & Public Works

TREATMENT PLANT APPROVAL No. 10/2021
Plumbing and Drainage Act 2018

SCHEDULE

Attachment 1

Specifications for the

OzziKleen GTS10

Treatment Plant Approval

Approved by: Stacey McInnes

Delegated Authority

Department of Energy & Public Works



SPECIFICATIONS

Parameter	Raw Greywater Characteristics	
Greywater treatment capacity	10 persons EP at 200 l/person/day	
Maximum hydraulic load	2,000 l/day	
Biological Oxygen Demand (BOD ₅)	300 mg/litre or 60 g/day/person	
Total Suspended Solids (TSS)	300 mg/litre or 60 g/day/person	
Total grease and oils	75 mg/litre	
Greywater temperature range	10°C to 38°C	
Parameter	Effluent Standard: Guaranteed (90 th percentile)	Effluent Standard: Test Results (90 th percentile)
BOD ₅	< 10 mg/l	< 4 mg/l
Suspended Solids	< 10 mg/l	< 8 mg/l
Total Nitrogen	< 20 mg/l	< 16.7 mg/l
Total Phosphorous	< 10 mg/l	< 7.29 mg/l
Thermotolerant Coliforms	< 10 colonies per 100 ml	0 colonies per 100 ml
Free Chlorine	> 0.5 -- < 4.0 mg/l	< 4.0 mg/l
Effluent is suitable for toilet flushing / washing machine reuse		

Treatment Plant Construction:

Tank and components	Polyethylene (MDPE)
All Pipe work	PVC

Electrical Equipment:

Air Blower	85 litre/min
Effluent Pump	Submersible
Controls	Electronic

Alarm System:

Alarm System	12 Volt Audio/Visual
Alarm signal	Indicator lights for Power, Blower

Aeration Tank:

Aeration tank volume	4850 litre
Residence time	46 hr

Disinfection equipment:

Chlorinator Type	Tablet Dispenser Cassette
Chlorine min contact time (max flow)	86 min

Motor Box:

Equipment Contained	Air Blower, Control Board, Decanter Solenoid Valve equipment
---------------------	---

Effluent Tank and Pump:

Effluent storage compartment volume	523 litres
Effluent pump duty	40 litres/min @ 8 m head
Pump Mounting	Suspended on discharge pipe

Irrigation Equipment: Basic irrigation equipment is supplied with the treatment plant. The irrigation system could be of several different formats. Check with Local Authority requirements.

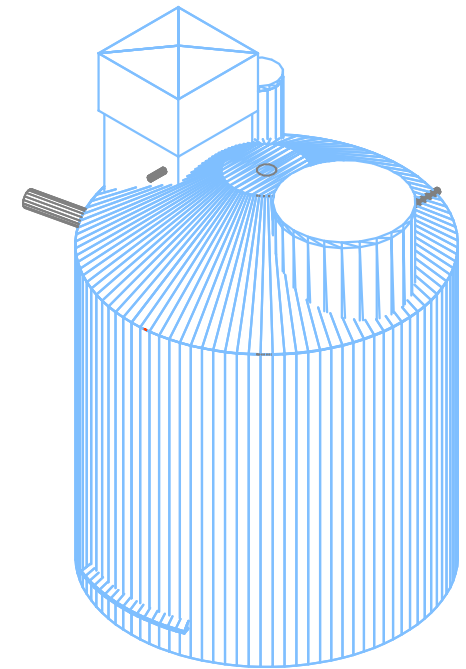
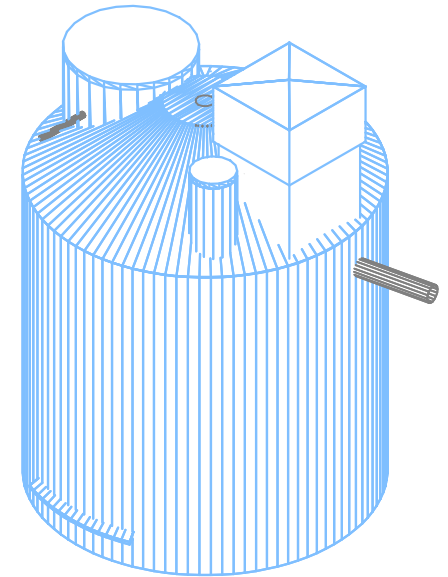
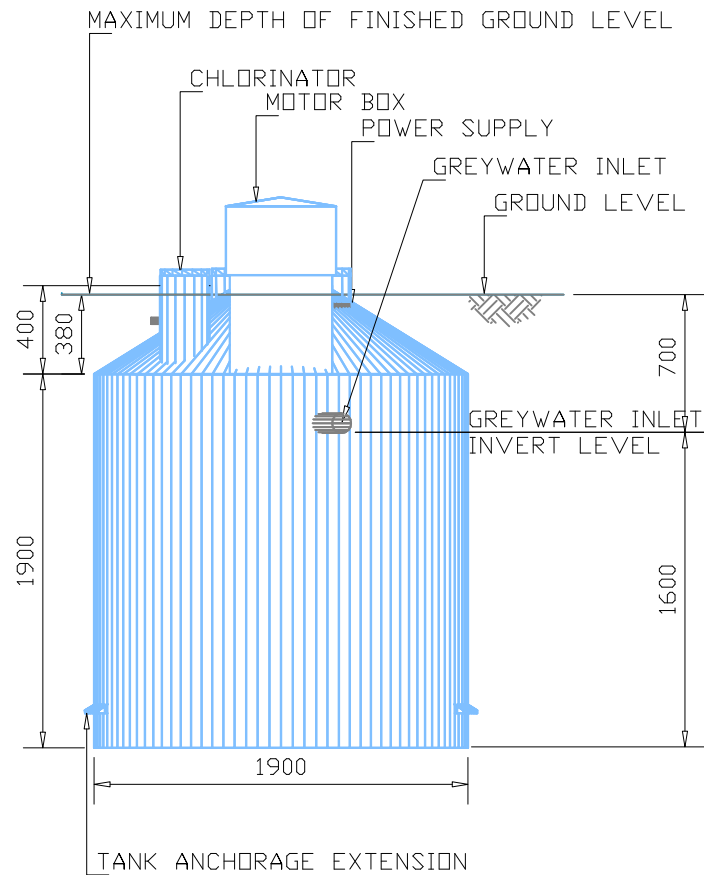
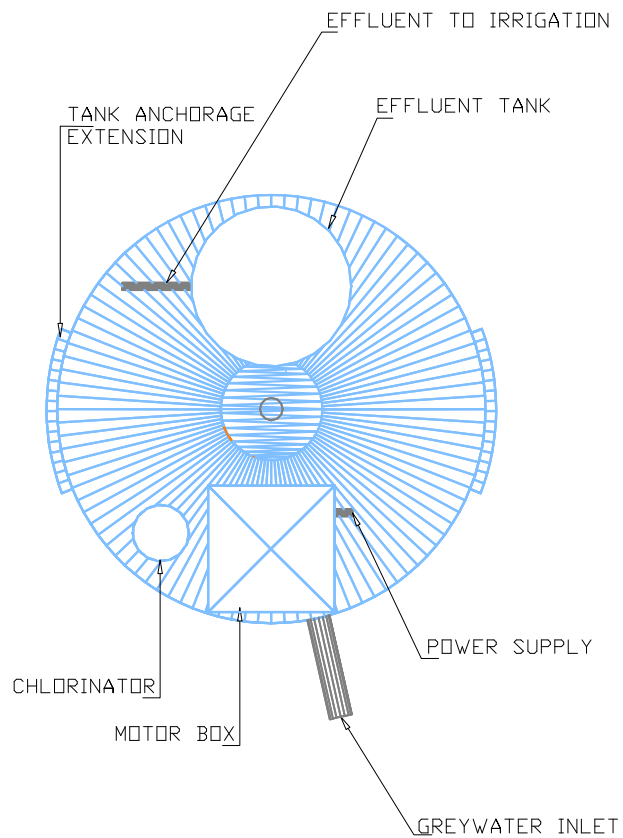

Treatment Plant Approval
 Approved by: Stacey McInnes
 Delegated Authority
 Department of Energy & Public Works



DATE	DESCRIPTION	REV.	BY
17/06/11	GENERAL REVISION	1	DC



Suncoast Waste Water Management

59 INDUSTRIAL AVE
 KUNDA PARK
 QLD 4556
 PH +61 7 5459 4900
 FAX +61 7 5456 4677
 www.ozzikleen.com

CLIENT	GENERAL	DESIGN	DC
PROJECT	GREYWATER TREATMENT SYSTEM	DRAWN	DC
TITLE	GTS10 – SYSTEM DETAILS	CHKD	MC
DWG NO.	GD-GTS10-H10.A	DATE	17/08/11
		SCALE	NTS